

LED WORK LIGHT

Reverse Approved

ABL

LED

ADR



D14288

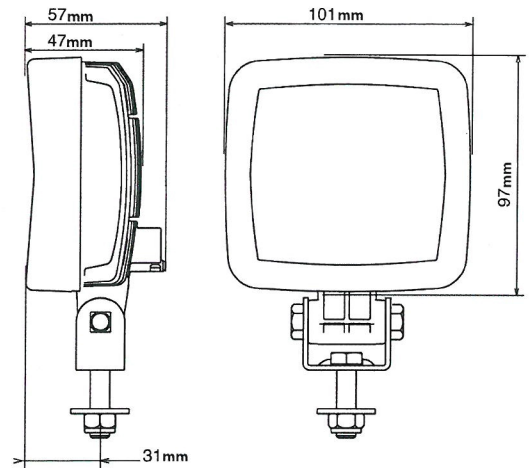

Energy saving - Power - Reliable - Robustness

- Source power : 1200 lumen
- Effective power : 850 lumen
- Consumption : 11W
- Lifetime : 20 000 hours
- Operating temp : -40°C to 60°C
- Connector : DT 2 ways
- Voltage : 12 - 36V
- Water tightness : IP69
- Housing : Aluminium

ABL optimizes the luminous flux and offers work lights that meet everyday demands. ABL product range is proven to be highly efficient and reliable in even the harshest operating conditions.

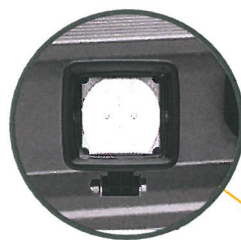
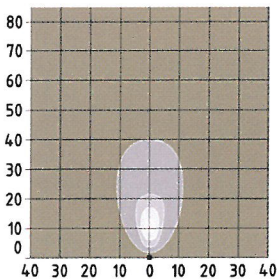

REVERSE APPROVED
- ECE R23 -



VIGNAL SYSTEMS
12, rue Eugène Hénaff - BP 594
F-69637 Vénissieux Cedex
Tel: +33 (0)4 72 90 29 29
Email: info@vignal-systems.com
Site Web: www.vignal-systems.com

