

Level	Zone	ECI N°.	Revision note	Date	Designed	Checked
R02	02	2020.002.1174	Updated tolerances.	2020/05/20	Würzl F.	Hinterb.M.

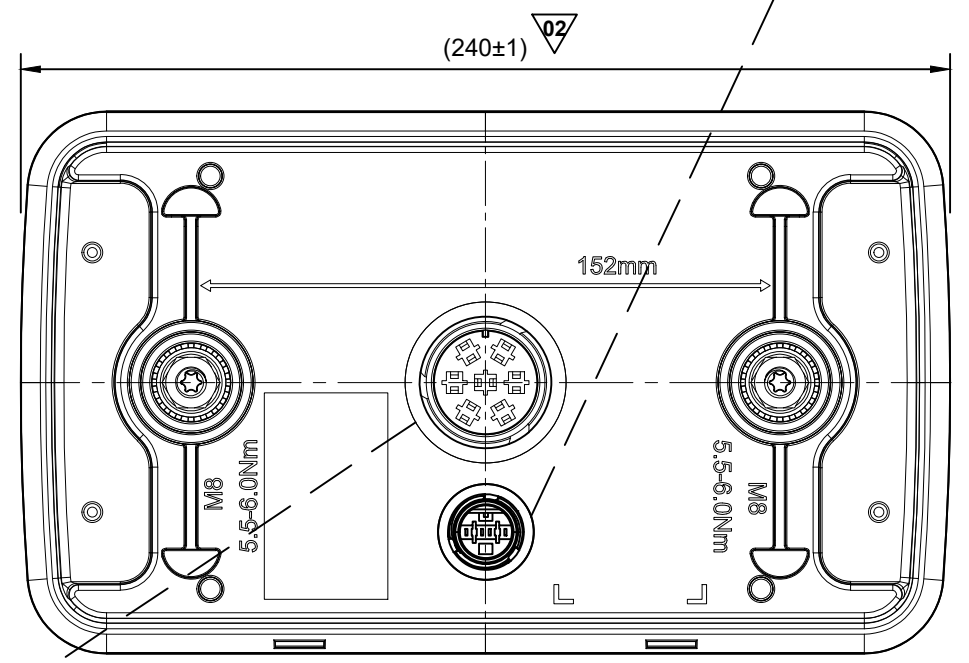

7p. ASS2.1	
FUNCTION	PIN
Blinker RH <i>DI RH</i>	1 / 4
Nebelschl. <i>Fog</i>	2
Masse <i>GND</i>	3
Rücklicht RH <i>Tail RH</i>	5
Bremse <i>Stop</i>	6
-	7
Rückfahrl. <i>Reverse</i>	8

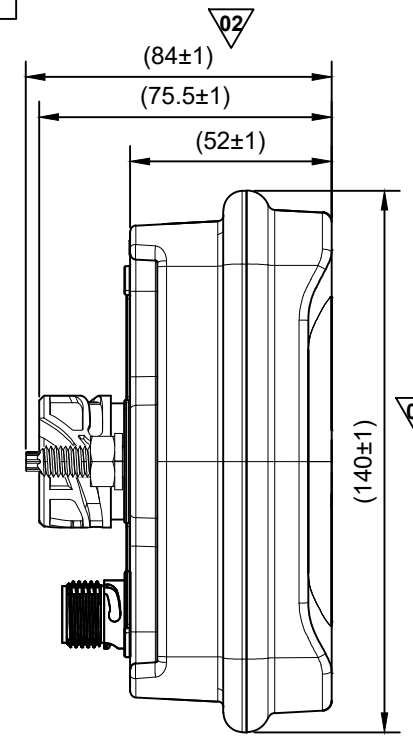
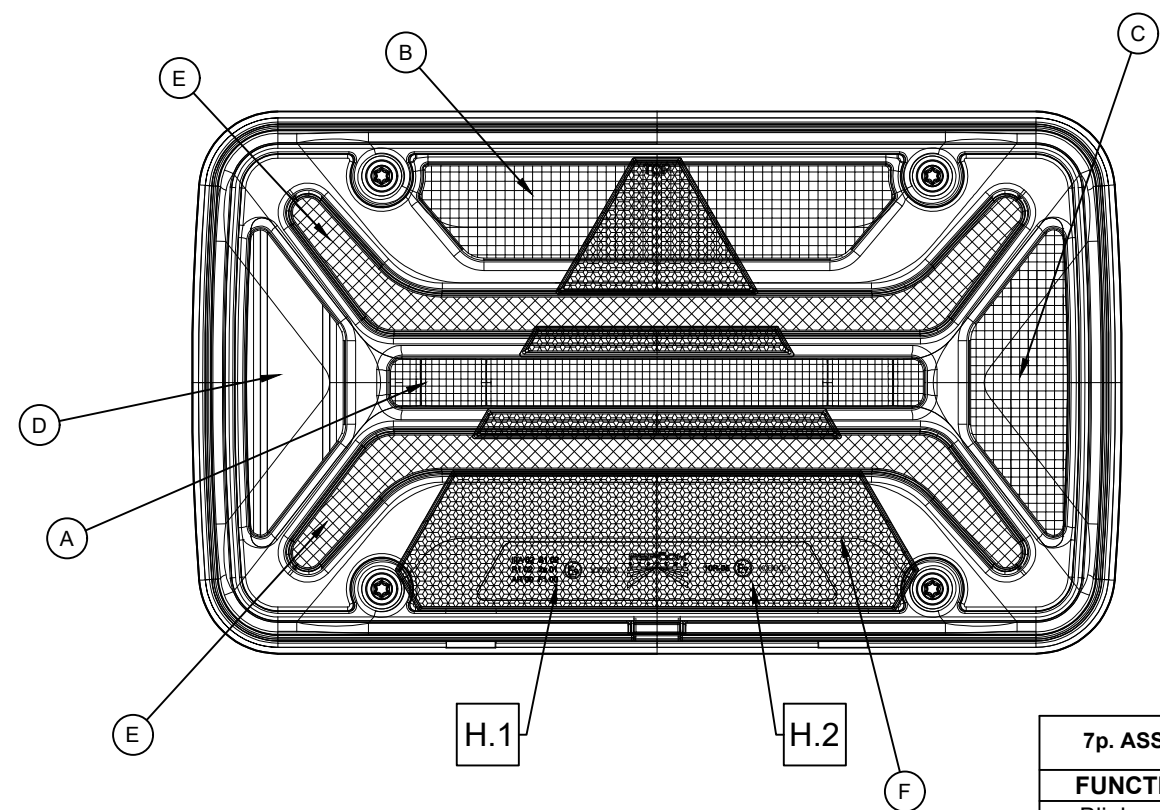
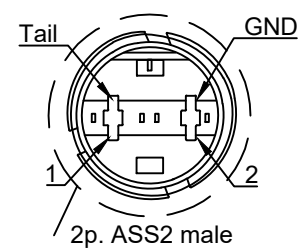
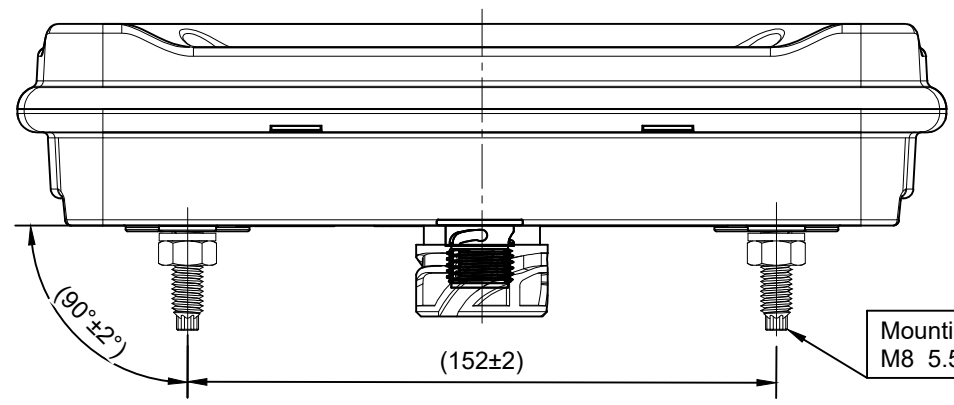
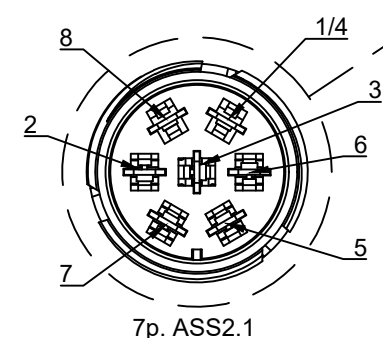

Electrical Specification				
Funktion <i>Function</i>	Nennspannung <i>Nominal Voltage</i>	Spannungsbereich <i>Voltage Range</i>	Nennstrom <i>Nominal Current</i>	Nennleistung <i>Nominal Power</i>
Volt (V)	Volt (V)	Volt (V)	Ampere (A)	Watt (W)
Tail	12V / 24V	9V - 32V	0.26A / 0.18A	3.1W / 4.3W
Stop	12V / 24V	9V - 32V	0.12A / 0.09A	1.4W / 2.2W
DI	12V / 24V	9V - 32V	0.14A / 0.17A	1.7W / 4.0W
Fog	12V / 24V	9V - 32V	0.17A / 0.12A	2.0W / 2.9W
Reverse	12V / 24V	9V - 32V	0.26A / 0.16A	3.1W / 3.8W

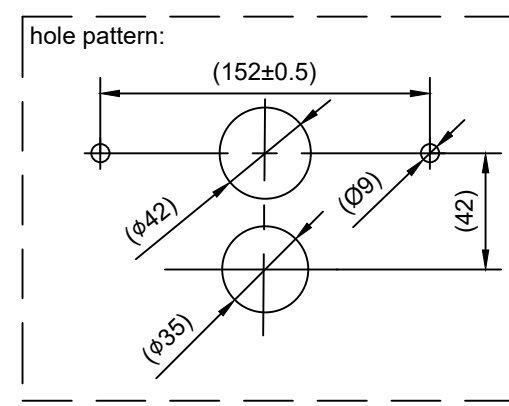

Homologation description							
H.1	E9	AR	F1	2a	S1	R1	IIIA
	22128	00	00	01	00	00	02
H.2	E9	10R					
	22128	06					

FUNCTION:	
Laufblinker RH LED <i>Progressive DI RH LED</i>	A
Bremse LED <i>Stop LED</i>	B
Nebelschl. LED <i>Fog LED</i>	C
Rückfahrl. LED <i>Reverse LED</i>	D
Rücklicht LED <i>Tail LED</i>	E
Reflektierendes Dreieck <i>Reflex reflector triangle</i>	F

Asp. Norm AAW075.04 () Auxiliary dimension DIN 406-10 [] Theoretical dimension ISO 1101
 Test dimension (SPC) [] Unfinished dimension DIN 406-10 [] Surface quality ISO 1302

Designed by Schrank Michael 2020/01/09 Checked by Strubreiter Daniel 2020/01/10 Approved by Enzlmüller Manuel 2020/01/13

ASPOCK SYSTEMS

Designation: MultiLED III - ASS2 7p.+ ASS2 2p.Tail RH
 Drawing Nr. 24893001
 Business Unit SALES - 24

Part Number: 24-8930-017

Dimensions in mm

Transmittal, reproduction, dissemination and/or editing of this document as well as utilization of its contents and communication there of to others without express authorization are prohibited. Offenders will be held liable for payment of damages. All rights created by patent grant or registration of a utility model or design patent are reserved.

DRAFT
 Project number 1174
 Tolerance: Asp. PAW 100.53b1
 Weight: - g
 Scale: x:x
 Level: R02
 Sheet: 1 / 1

